

TE SYSTEMS

OPERATING AND SERVICE MANUAL

MODEL 0510
MODEL 0510G
MODEL 0510S

HIGH-POWER VHF AMPLIFIER (Mobile/Base)
Revised January 2001

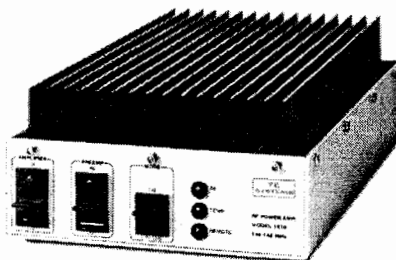

Important Notice

All material in this manual is copyrighted by TE Systems. No portion of it may be reproduced in any manner without the written permission of TE Systems.

Although the information contained in this manual has been thoroughly checked for accuracy and reliability, TE Systems shall have no liability or responsibility to customer or any other person or entity with respect to any liability, loss or damage caused or alleged to be caused directly or indirectly by products sold by TE Systems, including but not limited to any interruption of service, loss of business or anticipatory profits or consequential damages resulting from the use or operation of such products. Furthermore, TE Systems does not represent the described equipment as suitable for any purpose and does not assume any liability arising out of the application or use of any product described herein.

TE Systems reserves the right to make changes to any product or specifications described herein without notice.

TE SYSTEMS
P.O. Box 25845, Los Angeles, CA 90025 T(310)478-0591 F(310)473-4038

TABLE OF CONTENTS

SECTION

SECTION

I. GENERAL INFORMATION

- Description
- Specifications
- Instrument Identification
- Options
- Warranty
- Items Supplied

II. INSTALLATION

- Initial Inspection
- RF and DC Connections
- Mounting
- Power Supply Requirements
- Environmental Requirements

III. OPERATING INSTRUCTIONS

- Introduction
- Operation
 - RF Power Amp Turn-On
 - Receive Pre-Amp Turn-On
 - Mode Control
- Remote Control Features
- Temperature Considerations

IV. THEORY OF OPERATION

- RF Power Amplification
- Receive LNA
- T/R Switching
- Block Diagram
- Schematic Diagram
- Parts List

V. MAINTENANCE

- Introduction
- RF PA Adjustment
- Receive LNA Adjustment

SECTION I GENERAL INFORMATION

DESCRIPTION

THE TE SYSTEMS MODEL 0510G IS A RF AMPLIFIER SUBSYSTEM DESIGNED TO INTERFACE BETWEEN A 2-WAY TRANSCEIVER AND AN ANTENNA. THIS PRODUCT UNIQUELY INTEGRATES A HIGH POWER RF AMPLIFIER WITH A VERY LOW NOISE GAGS FET RECEIVE PREAMP THEREBY PROVIDING PERFORMANCE UNACHIEVABLE HERETOFORE. DURING TRANSMIT, THE UNIT FUNCTIONS BY LINEARLY AMPLIFYING THE TRANSCEIVER'S OUTPUT SIGNAL UP TO THE SPECIFIED POWER LEVEL. WHEN IN THE RECEIVE MODE, IT PERFORMS LIKE AN LNA (LOW-NOISE AMPLIFIER) BY AMPLIFYING THE RECEIVED SIGNAL WITH MINIMUM NOISE FIGURE.

A TYPICAL INSTALLATION IS SHOWN BELOW:

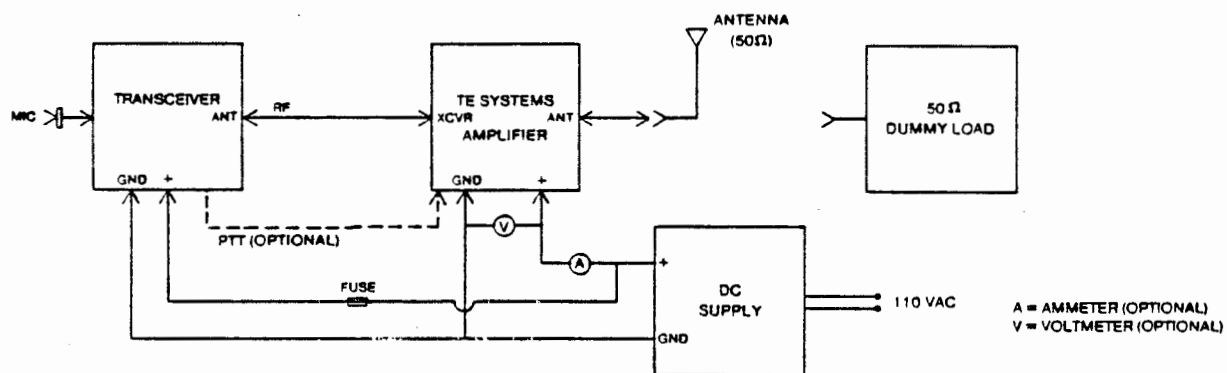

OPERATIONAL / TEST SET-UP FOR AMPLIFIER

THE MODEL 0510G FEATURES FRONT PANEL SWITCHES THAT CONTROL ALL RF FUNCTIONS. IN NORMAL TRANSCEIVE OPERATION, THE RF POWER AMP MAY BE USED ALONE, THE RECEIVE PREAMP LNA MAY BE USED ALONE, OR BOTH MAY BE SWITCHED ON. IN THE LATTER CASE, THE POWER AMP FUNCTIONS DURING TRANSMIT, AND THE RECEIVE LNA SWITCHES IN DURING RECEIVE. THIS MAKES THE UNIT FULLY COMPATIBLE WITH A TRANSCEIVER'S OPERATION.

FURTHER CONTROL CAN BE OBTAINED BY USING THE REMOTE CONTROL FUNCTIONS AVAILABLE THROUGH THE REMOTE JACK ON THE REAR OF THE UNIT. THE FOLLOWING FUNCTIONS ARE CONTROLLABLE: SWITCHING DELAY, PTT, AMPLIFIER IN/OUT, AND LED ILLUMINATION. ADDITIONALLY, THE SWITCHING DELAY CAN BE EASILY ADJUSTED BY A POTENTIOMETER CONTROL MOUNTED ON THE REAR PANEL.

THE ENTIRE UNIT IS HOUSED IN AN ATTRACTIVELY STYLED PAINTED ENCLOSURE DESIGNED TO FIT SECURELY TOGETHER FOR MAXIMUM STRENGTH AND MINIMUM WEIGHT. TWO OF THE FRONT PANEL SWITCHES HAVE LED STATUS LIGHTS TO PROVIDE VISUAL MONITORING OF THE UNIT'S CONTROL CONDITION, AND ADDITIONALLY THREE SEPERATE LED LIGHTS ARE USED TO PROVIDE READOUT OF THE UNIT'S OPERATING CONDITION: RF ON, OVERTEMP, AND EXTERNAL PTT. ALL CABLE INTERCONNECTION IS DONE ON THE REAR PANEL AND IS VISUALLY CONCEALED TO THE OPERATOR. THE UNIT IS SURFACE MOUNTED ON FOUR RUBBER FEET WITH THE HEATSINK FINS FACING UPWARDS THEREBY ALLOWING THE HEAT TO CONVECTION COOL. THE UNIT'S APPROXIMATE SIZE IS 2.8" X 5.8" X 10.5" (H,W,L).

SPECIFICATIONS

TE SYSTEMS MANUFACTURES A COMPLETE LINE OF HIGH POWER LINEAR RF AMPLIFIERS WITH OR WITHOUT LOW-NOISE GAAS FET PREAMPLIFIERS. THE SPECIFICATIONS FOR THIS PARTICULAR AMPLIFIER ARE SHOWN BELOW IN THE PRODUCT SPECIFICATION SUMMARY TABLE:

```

*****
***
***          MODEL 05106 PERFORMANCE SPECIFICATIONS          ***
***
*****
**
**  FREQUENCY          50-54          MHZ          **
**                    TUNED FOR 2 MHZ SEGMENT          **
**
**  INPUT POWER       10          WATTS, NOMINAL          **
**
**  OUTPUT POWER      170          WATTS, MINIMUM          **
**
**  CLASS OPERATION
**      PA            AB          LINEAR          **
**      PREAMP        A          LINEAR          **
**
**  T/R SWITCHING SENS. 0.6          WATT, TYPICAL          **
**
**  ANTENNA VSWR       3:1          MAXIMUM          **
**
**  RECEIVE PREAMP GAIN 15          DB, NOMINAL MIN.          **
**
**  RECEIVE PREAMP NF  .6          DB, NOMINAL          **
**
**  DC SUPPLY          13.6          VDC          **
**                    25          A, NOMINAL          **
**
**  SIZE              2.8 X 5.8 X 10.5 (H,W,L")          **
**
**  WEIGHT             4          LBS          **
**
*****

```

THE REQUIRED SYSTEM IMPEDANCE IS 50 OHMS UNBALANCED. A PROPER ANTENNA LOAD IMPEDANCE MUST BE PRESENTED TO THE RF POWER AMPLIFIER DURING TRANSMIT. LOAD VSWRS EXCEEDING 3:1 ARE NOT RECOMMENDED AND MAY CAUSE TRANSISTOR FAILURE DUE TO POWER IMBALANCES WITHIN THE UNIT OR EXCESSIVE DEVICE POWER DISSIPATION. TE SYSTEMS RECOMMENDS CHECKING THE ANTENNA'S VSWR BEFORE APPLYING FULL POWER FROM THE AMPLIFIER.

THE RATED DUTY OF THE AMPLIFIER IS 50% USING NORMAL COMMUNICATION TRANSMISSION PERIODS (ICAS). LONGER DUTY TRANSMISSIONS REQUIRE EITHER FORCED AIR COOLING OF THE HEATSINK FINS OR POWER DERATING OR BOTH. CHECK WITH TE SYSTEMS OR ITS AGENT FOR RECOMMENDED OPERATING CHANGES FOR HIGHER DUTY USAGE.

INSTRUMENT IDENTIFICATION

TE SYSTEMS' RF POWER AMPLIFIERS HAVE THEIR MODEL NUMBERS SPECIFIED ON THE RIGHT SIDE OF THE FRONT OPERATING PANEL BENEATH THE TE SYSTEMS NAME. ADDITIONALLY, THE FREQUENCY RANGE CAPABILITY FOR THE UNIT IS IDENTIFIED IN MEGAHERTZ.

ON THE REAR PANEL, THE MODEL NUMBER AND THE SERIAL NUMBER ARE INSCRIBED ON THE METALLIZED LABEL. THIS ALSO HAS THE FCC IDENTIFYING NUMBER FOR TYPE ACCEPTANCE. THE COMPLETE FABRICATION AND PERFORMANCE HISTORY OF EACH UNIT IS MAINTAINED AT TE SYSTEMS FOR RECORD PURPOSES. ALL CORRESPONDENCE CONCERNING EACH UNIT SHOULD INCLUDE THE COMPLETE MODEL AND SERIAL NUMBER.

OPTIONS

RF POWER AMPLIFIERS WITH NO GAAS FET PREAMP CAN BE FACTORY MODIFIED TO INCORPORATE THE INTERNAL PREAMP. THIS REQUIRES A FRONT PANEL CHANGE, INSTALLATION OF THE INTERNAL PREAMP WITH NOISE FIGURE OPTIMIZATION TUNING, AND A COMPLETE PERFORMANCE CHECKOUT. ARRANGEMENTS WITH TE SYSTEMS MUST BE MADE ON THIS MATTER BEFORE THE MODIFICATION CAN BE MADE.

RETUNING THE AMPLIFIER, PREAMP OR BOTH CAN BE PERFORMED BY TE SYSTEMS AT ANY DATE AFTER PURCHASE. PREARRANGEMENT WITH TE SYSTEMS OR ITS AGENT MUST BE MADE BEFORE THIS CAN BE PERFORMED. RETUNING THE UNIT TO FREQUENCIES COVERED BY OTHER MODELS IS NOT POSSIBLE.

OTHER HARDWARE OPTIONS, SUCH AS MOUNTING BRACKETS, ARE AVAILABLE FROM TE SYSTEMS OR ITS AGENT. CONTACT THEM FOR CURRENT OPTION PART NUMBERS, PRICING, AND AVAILABILITY.

**TE
SYSTEMS**

WARRANTY

This TE Systems product is warranted against defects in materials and workmanship for a period of one year from the date of shipment, except that in the case of certain components listed below, the warranty shall be for the specified period.

SPECIFIC COMPONENTS	WARRANTY PERIOD
RF POWER TRANSISTORS	1 YEAR
LOW NOISE GAAS FET	6 MONTHS

TE Systems will, at its option, repair or replace products which prove to be defective during the warranty period provided they are returned to TE Systems, or its Agent, and provided the proper operating specifications and preventive maintenance procedures as listed in this manual are followed. Repairs necessitated by misuse of the product are not covered by this warranty. No other warranties are expressed or implied, including but not limited to the implied warranties of merchantability and fitness for a particular purpose. TE Systems is not liable for consequential damages.

WARNING

Power transistor damage and/or other component failure may occur if improper antenna load impedance is connected to the output port during transmit. See specifications section for proper antenna load impedance.

IF A DEFECT SHOULD OCCUR DURING THE WARRANTY PERIOD, DO NOT ATTEMPT TO REPAIR THE AMPLIFIER. INSTEAD, CONTACT TE SYSTEMS OR ITS AGENT FOR INSTRUCTIONS ON EITHER RETUNING THE UNIT PER THE MAINTENANCE SECTION OF THIS MANUAL OR RETURNING IT. UNITS RETURNED MUST BE FREIGHT PREPAID, PACKAGED CAREFULLY TO PREVENT SHIPPING DAMAGE, INSURED TO THE FULL VALUE, AND COMPLETELY ASSEMBLED. THE WARRANTY WILL BE VOIDED IF THE EQUIPMENT IS RETURNED SHOWING SIGNS OF ATTEMPTED REPAIRS OR IS ALTERED IN ANY WAY.

** NOTE - THE REGISTRATION CARD MUST BE SUBMITTED WITHIN 10 DAYS OF PURCHASE TO VALIDATE THE EQUIPMENT'S WARRANTY - AVAILABLE ONLY TO THE ORIGINAL OWNER.

ITEMS SUPPLIED

THE FOLLOWING ITEMS ARE SUPPLIED WITH THE RF POWER AMPLIFIER AS PARTS REQUIRED TO PROPERLY OPERATE THE ELECTRONIC EQUIPMENT:

QUANTITY -----	DESCRIPTION -----
1	OPERATING MANUAL
1	DC POWER RECEPTACLE, 4 PIN FEMALE
1	REMOTE PLUG, 7 PIN MALE

SECTION II

INSTALLATION

INITIAL INSPECTION

THE RF AMPLIFIER HAS BEEN CAREFULLY INSPECTED BOTH MECHANICALLY AND ELECTRICALLY BEFORE SHIPMENT, AND IT SHOULD BE FREE OF MARKS AND SCRATCHES AND IN GOOD ELECTRICAL ORDER UPON RECEIPT. THE UNIT SHOULD BE CHECKED TO VERIFY THAT NO PHYSICAL DAMAGE HAS OCCURRED IN TRANSIT. IF THERE IS DAMAGE, PLEASE RETAIN THE SHIPPING CARTON AND PADDING MATERIAL FOR THE CARRIER'S INSPECTION, AND IMMEDIATELY NOTIFY TE SYSTEMS OR ITS AGENT.

RF AND DC CONNECTIONS

THE TE SYSTEMS AMPLIFIER UNIT MAY BE PROPERLY INSTALLED BY INSERTING IT BETWEEN A TRANSCEIVER AND THE ANTENNA. THE REAR PANEL RF CONNECTOR LABELLED "XCVR" IS COAXIALLY CONNECTED TO THE TRANSCEIVER'S ANTENNA PORT. THE CONNECTOR LABELLED "ANT" IS THEN CONNECTED TO THE ANTENNA. GOOD LOW-LOSS, HIGH QUALITY 50 OHM COAX CABLE SHOULD BE USED FOR BOTH OF THESE INTERCONNECTIONS.

THE INSTALLATION CONNECTION IS SHOWN BELOW:

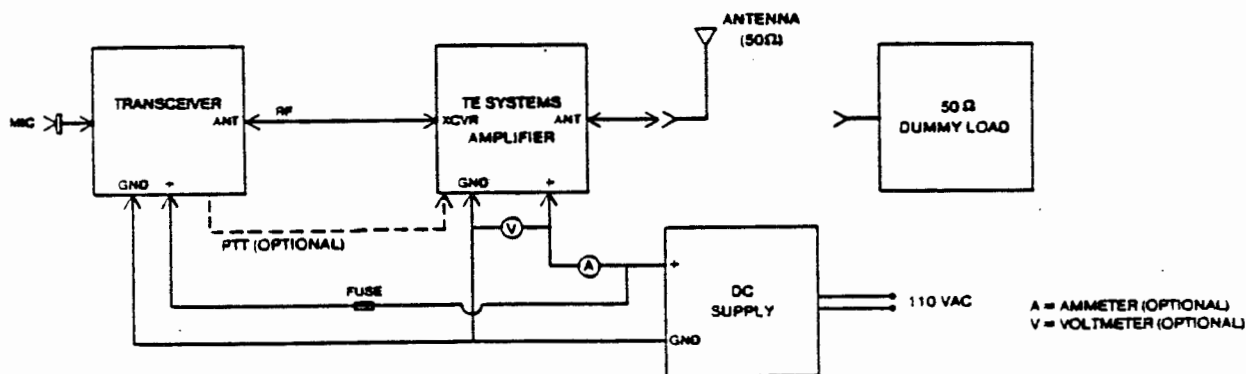

OPERATIONAL / TEST SET-UP FOR AMPLIFIER

POWER IS SUPPLIED TO THE AMPLIFIER VIA THE 4-PIN DC CONNECTOR ON THE REAR PANEL. THE TWO VERTICAL PINS CLOSEST TO THE FUSE HOLDER ARE FOR THE +13.6 VDC. THE TWO HORIZONTAL PINS CLOSEST TO THE REMOTE SOCKET ARE FOR GROUND. SEE THE REAR PANEL DIAGRAM BELOW:

BACK VIEW - DC VOLTAGE CONNECTION

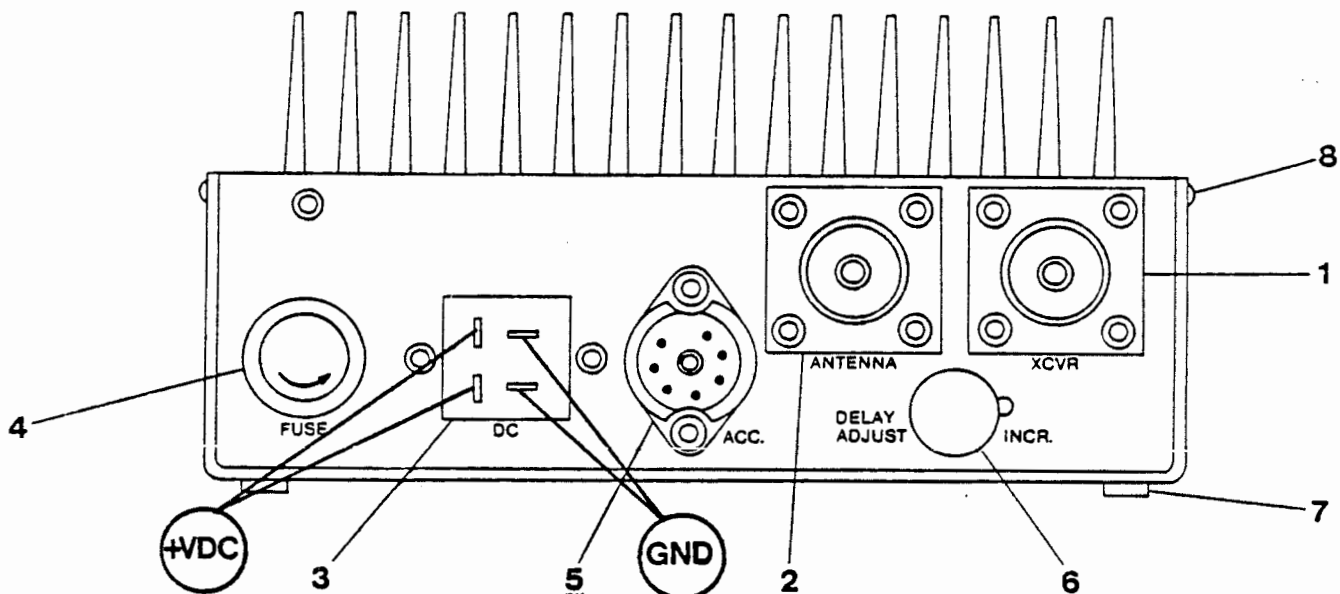

BACK VIEW - INTERCONNECTION IDENTIFICATION

```

*****
***
***          REAR PANEL INTERCONNECTION TABLE          ***
***
*****
**
**      1.  RF INPUT CONNECTOR (CONNECT TO XCVR)      **
**
**      2.  RF OUTPUT CONNECTOR (CONNECT TO ANTENNA)  **
**
**      3.  DC CONNECTOR                               **
**
**      4.  FUSE                                       **
**
**      5.  REMOTE ACCESSORY SOCKET                    **
**
**      6.  DELAY AJUST CONTROL (CW-SSB MODE ONLY)    **
**
**      7.  RUBBER MOUNTING FEET                       **
**
**      8.  COVER ATTACHMENT SCREWS                   **
**
*****

```

ADDITIONALLY, THE REMOTE SOCKET MAY BE USED FOR PTT OR DISABLING THE AMPLIFIER. PLEASE REFER TO THE SECTION ON REMOTE CONTROL FEATURES FOR INFORMATION ON THIS CONNECTION.

MOUNTING

THE RF AMPLIFIER IS EQUIPPED WITH FOUR RUBBER MOUNTING FEET ON THE BOTTOM COVER AND THEY FUNCTION TO KEEP THE UNIT SECURE ON A TABLE TOP SURFACE. THE VARIOUS CABLE INTERCONNECTIONS SHOULD BE ATTACHED ON THE REAR PANEL AND ROUTED BACKWARDS OUT OF SIGHT.

NORMAL OPERATION OF THE UNIT WILL HAVE THE BLACK ANODIZED FINS UPWARDS TO ALLOW MAXIMUM CONVECTION COOLING. AN AIR SPACE MUST BE ALLOWED FOR THE CONVECTION COOLING TO OCCUR, OR ELSE OVERHEATING WILL OCCUR. THE USER SHOULD EXPERIMENT TO DETERMINE HOW MUCH AIR SPACE IS NEEDED FOR HIS PARTICULAR INSTALLATION AND OPERATING TECHNIQUE.

AS AN OPTION, A MOUNTING BRACKET (TE SYSTEMS P/N 1035) CAN BE FITTED TO THE AMPLIFIER UNIT TO PERMIT MOUNTING THE AMPLIFIER FROM EITHER THE TOP OR BOTTOM SIDE. THE BRACKET HOLDS THE AMPLIFIER FIRMLY AND ALLOWS A SLIGHT UPWARD OR DOWNWARD TILT TO PROVIDE EASE OF PANEL CONTROL. ATTACHMENT OF THE BRACKET ONTO THE AMPLIFIER IS DONE TO THE SIDES OF THE AMPLIFIER BODY USING EXISTING TAPPED HOLES SO NO ADDITIONAL HARDWARE MODIFICATIONS ARE NECESSARY.

IN SOME APPLICATIONS, THE USER MAY WANT TO MECHANICALLY ATTACH HIS UNIT TO ANOTHER SURFACE. IN THIS CASE, THE COVER MAY BE REMOVED AND HOLES DRILLED OR PUNCHED IN IT AS DESIRED TO ALLOW THE PROPER ATTACHMENT. WHEN REMOVING THE COVER/LID, NOTE THE ORIGINAL FIT AS THE COVER IS NOT COMPLETELY SYMMETRICAL. AFTER SECURING THE LID WITH THE NEW ATTACHMENT SCHEME, IT IS REUNITED WITH THE AMPLIFIER BODY USING THE EIGHT BLACK HOLDING SCREWS.

SINCE THE UNIT IS SUPPLIED WITH A TIGHT FITTING COVER TO MINIMIZE RF RADIATION AND REDUCE FOREIGN PARTICLE CONTAMINATION, ANY MODIFICATIONS TO THE COVER SHOULD BE CONSISTENT WITH THE ORIGINAL DESIGN INTENT.

POWER SUPPLY REQUIREMENTS

THE MODEL 05106 RF AMPLIFIER HAS THE FOLLOWING MAXIMUM PEAK CURRENT REQUIREMENT:

MODEL 05106

25 AMPS NOMINAL

TE SYSTEMS RECOMMENDS A 13.6 VOLT DC SUPPLY HAVING AT LEAST A 20% HIGHER CONTINUOUS CURRENT RATING THAN THAT REQUIRED BY THE AMPLIFIER. IF OTHER EQUIPMENT IS TO BE OPERATED ALSO ON THE DC SUPPLY, THEN THE CUMULATIVE AMPERAGE REQUIREMENTS SHOULD BE USED FOR THE COMPUTATION.

IF EXCESSIVELY LONG TRANSMISSIONS ARE ANTICIPATED, THEN A HIGHER CURRENT RATED SUPPLY MAY BE DESIRABLE. IF THE POWER SUPPLY ENCLOSURE TEMPERATURE REACHES 50 DEGREES CENTIGRADE OR HIGHER DURING OPERATION, FAN COOLING MAY BE NECESSARY TO CONVECTION COOL THE UNIT DOWN TO ITS SAFE OPERATING AREA. CHECK WITH THE SUPPLY MANUFACTURER TO VERIFY ITS CAPABILITIES.

ENVIRONMENTAL REQUIREMENTS

TE SYSTEMS RF AMPLIFIERS ARE DESIGNED TO OPERATE OVER THE TEMPERATURE RANGE OF 0 TO +60 DEGREES CENTIGRADE. THE RF AMPLIFIER UNIT WILL MEET THE PERFORMANCE SPECIFICATIONS WHEN OPERATING WITHIN THE TEMPERATURE RANGE OF 10 TO 40 DEGREES CENTIGRADE. ABOVE AND BELOW THIS RANGE AND WITHIN THE TEMPERATURE PERFORMANCE LIMITS, THE UNIT WILL OPERATE SATISFACTORILY BUT THE PARAMETERS OF PERFORMANCE MAY OR MAY NOT BE WITHIN THE SPECIFICATION.

THE UNIT WILL PROBABLY OPERATE SATISFACTORILY WELL BELOW 10 DEGREES CENTIGRADE, BUT DAMAGE TO THE AMPLIFIER MAY OCCUR WITH OPERATION ABOVE +65 DEGREES CENTIGRADE. THE DAMAGE OCCURS DUE TO THE OVERHEATING OF THE ACTIVE JUNCTION AREA AND EMITTER FINGER RESISTORS WITHIN THE TRANSISTOR. THE RESULT MAY BE POWER AND GAIN LOSS THAT IS IRRETRIEVABLE.

A THERMOSTAT IS INCORPORATED WITHIN THE UNIT TO TEMPORARILY DISABLE THE AMPLIFYING MODE ONCE THE HEATSINK TEMPERATURE EXCEEDS +65 DEGREES. THE SWITCH HAS SOME HYSTERISIS SO THAT OPERATION IS NOT RESTORED UNTIL THE TEMPERATURE DROPS DOWN 15 DEGREES.

WHILE THE UNIT HAS A TIGHT FITTING COVER THAT ALLOWS MINIMUM FOREIGN MATERIAL COLLECTION WITHIN THE UNIT, IT IS NOT A WEATHER TIGHT SEAL. MOUNTING OF THE AMPLIFIER AT OR NEAR THE ANTENNA WITHOUT ENVIRONMENTAL PROTECTION MAY SEVERELY DEGRADE THE MECHANICAL INTEGRITY OF THE UNIT. IF SUCH OPERATION IS DESIRABLE, THE UNIT MUST BE PROTECTED FULLY FROM MOISTURE COLLECTION, SALT SPRAY, OR OTHER DETRIMENTAL ENVIRONMENTAL STRESSES.

SECTION III

OPERATING INSTRUCTIONS

INTRODUCTION

THE MODEL 0510G IS A RF POWER AMPLIFIER AND RECEIVE PREAMP COMBINATION HOUSED TOGETHER IN ONE UNIT. UPON TRANSMIT THE UNIT FUNCTIONS TO AMPLIFY THE TRANSMITTED SIGNAL UP TO THE SPECIFIED POWER LEVEL. SWITCHING THE TRANSCEIVER BACK TO THE RECEIVE MODE CAUSES THE AMPLIFIER TO SIMULTANEOUSLY SWITCH INTO EITHER THE STRAIGHT THROUGH OR LNA PREAMP MODE. THE UNIT CAN FUNCTION IN VARIOUS COMBINATIONS OF THE ABOVE DEPENDING UPON THE USER SELECTED SWITCH SETTINGS. OPERATION STATUS LIGHTS MOUNTED ON THE FRONT CONTROL PANEL INDICATE THE OPERATING CONDITION OF THE UNIT DURING OPERATION. A COMPLETE PROCEDURE FOR OPERATION OF THE UNIT IN ITS VARIOUS MODES IS DETAILED IN THE FOLLOWING PARAGRAPHS.

OPERATION

THE MODEL 0510G RF AMPLIFIER IS DESIGNED TO AMPLIFY THE TRANSMITTED INPUT RF SIGNAL UP TO THE SPECIFIED OUTPUT LEVEL AND PERFORM LOW NOISE SIGNAL AMPLIFICATION ON RECEIVE. THE RESULT IS A MUCH STRONGER SIGNAL ON TRANSMIT WITH A SUPERIOR LISTENING SYSTEM ON RECEIVE.

THE BASIC OPERATION OF THE UNIT IS DESCRIBED IN THE SECTIONS BELOW. BEFORE BECOMING FAMILIAR WITH THE FEATURES OF THIS UNIT, THE AMPLIFIER UNIT SHOULD BE CONNECTED PROPERLY AS SHOWN BELOW AND DESCRIBED FULLY IN THE RF AND DC CONNECTIONS SECTION OF THIS MANUAL.

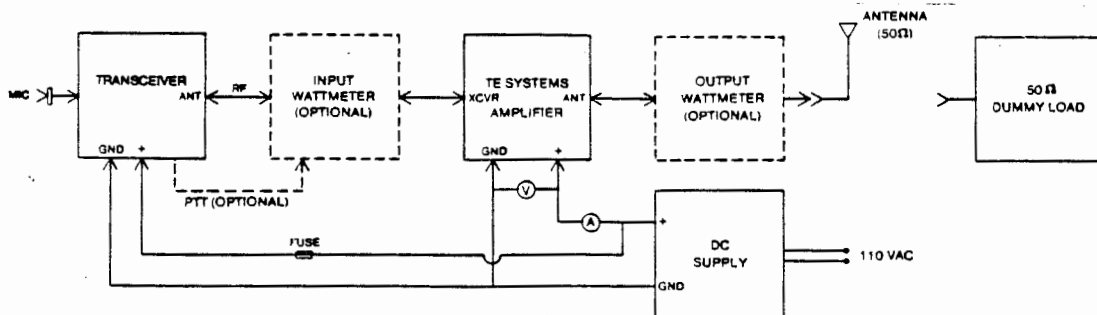

OPERATIONAL / TEST SET-UP FOR AMPLIFIER

NOTE - IN THE OPERATIONAL/TEST SET-UP BLOCK DIAGRAM, THE USE OF INPUT AND/OR OUTPUT WATTMETERS IS OPTIONAL, BUT THEY MAY BE USEFUL IN DETERMINING THE PROPER OPERATION OF THE AMP. FOR EXAMPLE, THE AMPLIFIER'S INPUT TUNING MAY BE OPTIMIZED FOR THE PROPER MATCH TO THE DRIVING EXCITER. THIS IS ACCOMPLISHED BY TUNING THE AMPLIFIER'S INPUT TUNING TRIMMER (LOCATED INSIDE THE UNIT) FOR MINIMUM REFLECTED POWER AS MEASURED ON THE INPUT POWER METER. IN THE FORWARD POSITION, THE POWER METER MEASURES THE INPUT POWER APPLIED TO THE AMPLIFIER. THIS MEASUREMENT SHOULD BE DONE AT THE AMPLIFIER'S INPUT PORT. REFER TO SECTION V FOR DETAILS ON PERFORMING THIS PROCEDURE.

AT THE OUTPUT OF THE AMPLIFIER, THE IMPEDANCE MATCH TO THE ANTENNA MAY BE OPTIMIZED BY TUNING THE AMPLIFIER'S OUTPUT TRIMMER (LOCATED INSIDE THE UNIT) FOR MAXIMUM OUTPUT POWER AS MEASURED ON THE OUTPUT POWER METER. REFER TO SECTION V FOR DETAILS ON PERFORMING THIS PROCEDURE.

THE VSWR OF THE ANTENNA MAY BE CHECKED BY MEASURING THE REFLECTED POWER. THE RESULTANT VSWR CAN BE CALCULATED FROM THE FORMULA:

$$VSWR = \frac{1 + \sqrt{R/F}}{1 - \sqrt{R/F}}$$

WHERE R = REFLECTED POWER IN WATTS, AND F = FORWARD POWER IN WATTS. IN CASES WHERE THERE ARE LARGE RELECTED POWERS, THE ACTUAL POWER (P) DELIVERED TO THE ANTENNA IS:

$$P = F - R \quad \text{WATTS}$$

REMEMBER THAT THE ACCURACY OF THE INPUT AND OUTPUT POWERS DEPENDS ON THE MEASURING EQUIPMENT USED. POWER METERS SUCH AS THE BIRD 43 ARE ACCURATE TO +- 5% AT FULL SCALE ONLY AND WITH OUTPUT POWERS OF 170 WATTS, THE MEASUREMENT ERROR CAN BE +- 10 WATTS OR MORE WHEN USING A 250 WATT SLUG.

A) RF POWER AMP TURN-ON

WITH THE UNIT CONNECTED AS SHOWN IN THE OPERATIONAL/TEST SETUP DIAGRAM ON PAGE 3-1, NEXT REFER TO THE FRONT VIEW DIAGRAM BELOW. WITH ALL CONTROL SWITCHES IN THE OFF POSITION, THE AMPLIFIER WILL NOT BE FUNCTIONED ON AND, THEREFORE, IT WILL ACT AS A STRAIGHT THROUGH INTERCONNECTION PROVIDING NO SIGNAL AMPLIFICATION.

TURNING ON THE AMPLIFIER SWITCH HAS NO EFFECT UPON RECEIVE, BUT WILL SWITCH-IN THE POWER AMPLIFIER DURING TRANSMIT. THE GREEN STATUS LIGHT SHOULD ILLUMINATE TO VERIFY THE "IN" READY CONDITION OF THE AMPLIFIER. PLEASE REFER TO THE SPECIFICATIONS FOR THE PARTICULAR MODEL TO DETERMINE THE LEVELS OF RF INPUT AND OUTPUT POWER. ALSO MAKE SURE A PROPER ANTENNA LOAD IS CONNECTED.

THE AMPLIFIER SWITCHES "IN" WHEN IT SEES A RF TRANSMITTED SIGNAL APPLIED FROM THE TRANSCEIVER. THIS TECHNIQUE IS KNOWN AS RF SENSING, WHEREIN, THE TRANSMITTED SIGNAL ACTIVATES THE AMPLIFIER'S RELAY SWITCHING CIRCUITS. ALTERNATIVELY, THE PTT REMOTE CONNECTION MAY BE USED TO "HARD KEY" THE AMPLIFIER. IN THIS CASE THE AMPLIFIER IS SWITCHED IN ANYTIME THE TRANSCEIVER GOES INTO TRANSMIT. SOME USERS MAY FIND THIS ADVANTAGEOUS TO ELIMINATE RF SWITCHING DURING NO RF PERIODS SUCH AS PAUSES IN SSB TRANSMISSION. THE ACTUAL RF SWITCHING TIME IS MINIMIZED TOO WITH PTT CONTROL (THE MODE SWITCH SHOULD BE IN THE FM MODE FOR MINIMUM TIME DELAY).

FRONT VIEW

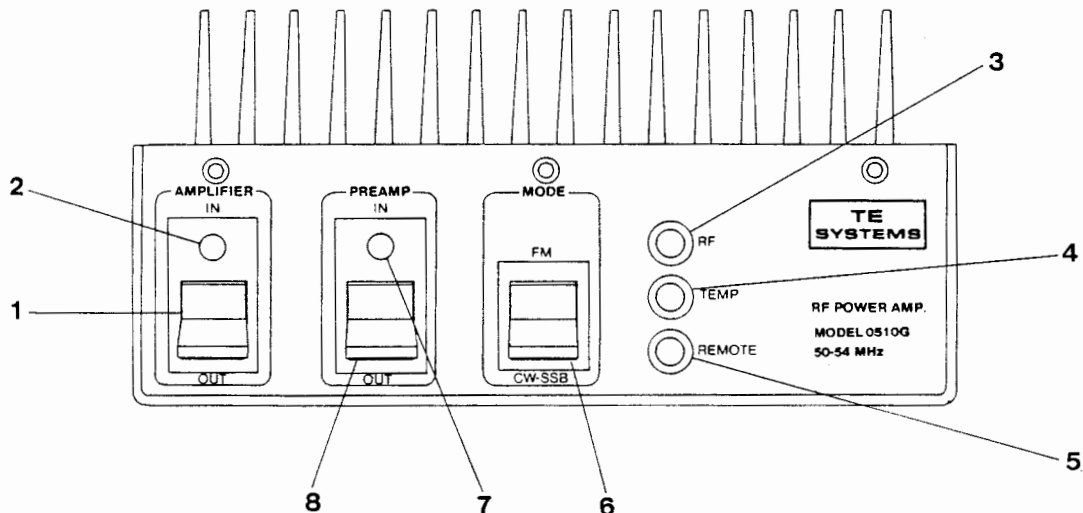

```

*****
***
***          FRONT PANEL DESCRIPTION  TABLE          ***
***
*****
**
**          1.  RF POWER AMP IN/OUT SWITCH          **
**
**          2.  RF POWER AMP IN/OUT STATUS LIGHT (GREEN) **
**
**          3.  RF LIGHT(RED) - ILLUMINATES WHEN THE UNIT **
**              GOES INTO THE RF POWER AMPLIFYING **
**              CONDITION **
**
**          4.  TEMP LIGHT(RED) - ILLUMINATES WHEN THE **
**              UNIT'S HEATSINK TEMPERATURE RISES **
**              ABOVE +65 DEG CENTIGRADE **
**
**          5.  REMOTE LIGHT(RED) - ILLUMINATES WHEN THE **
**              REMOTE PTT INPUT HAS BEEN KEYED **
**
**          6.  MODE SWITCH - CONTROLS RELAY SWITCH DELAY **
**
**          7.  PREAMP IN/OUT STATUS LIGHT (GREEN) **
**
**          8.  PREAMP IN/OUT SWITCH **
**
*****

```

B) RECEIVE PREAMP TURN-ON

WITH THE UNIT CONNECTED AS SHOWN IN THE OPERATIONAL/TEST SETUP DIAGRAM SHOWN ON PAGE 3-1, NEXT REFER TO THE FRONT VIEW DIAGRAM. WITH ALL CONTROL SWITCHES IN THE OFF POSITION, THE AMPLIFIER WILL NOT BE FUNCTIONED ON AND, THEREFORE, IT WILL ACT AS A STRAIGHT THROUGH INTERCONNECTION PROVIDING NO SIGNAL AMPLIFICATION.

TURNING ON THE PREAMP SWITCH CAUSES THE INTERNAL LOW-NOISE AMPLIFIER (LNA) TO BE SWITCHED IN DURING RECEIVE AND TO BE KEYED OUT DURING TRANSMIT. THIS SWITCH MAY BE USED TOGETHER OR SEPARATELY FROM THE AMPLIFIER IN/OUT SWITCH. WHEN SWITCHED "IN" THE GREEN STATUS LIGHT SHOULD ILLUMINATE AND THE PREAMP SHOULD FUNCTION PER THE SPECIFICATIONS. UPON TRANSMIT, THE RF SENSING CIRCUIT SWITCHES OUT THE PREAMP TO PREVENT DAMAGE TO THE LNA SYSTEM, AND UPON RECEIVE THE PREAMP IS SWITCHED BACK IN.

C) MODE CONTROL

WITH THE MODE SWITCH UPWARDS IN THE "FM" POSITION, THE T/R SWITCHING DELAY TIME IS AT A MINIMUM. THIS ALLOWS FM OPERATION WITH FAST TWO-WAY TRANSMISSIONS AND NO NOTICABLE AMPLIFIER SWITCHING TIME.

WHEN THE MODE SWITCH IS IN THE "CW-SSB" POSITION, A TIME DELAY IS INCORPORATED IN THE T/R SWITCHING, AND THE DELAY TIME IS ADJUSTABLE FROM THE POTENTIOMETER LOCATED ON THE REAR PANEL. THIS DELAY FUNCTIONS TO HOLD THE AMPLIFIER IN THE AMPLIFY (TRANSMIT) MODE DURING PAUSES IN VOICE TRANSMISSION OR BREAKS BETWEEN CODE SENDING. DELAY PERIODS OF UP TO 2-4 SECONDS ARE AVAILABLE. NOTE THAT THE AMPLIFIER IS ALWAYS OPERATING IN THE LINEAR MODE REGARDLESS OF THE MODE SWITCH SETTING.

REMOTE CONTROL FEATURES

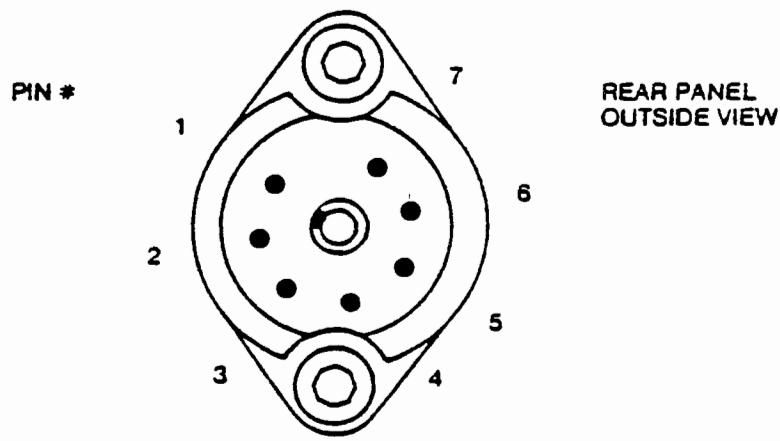

REMOTE ACCESSORY SOCKET

```

*****
***
***          REMOTE ACCESSORY SOCKET PINOUT          ***
***
*****
**
**  1.  FM/SSB EXTERNAL CONTROL                      **
**      WITH FRONT PANEL IN CW-SSB POSITION          **
**      GROUND FOR FM, OPEN FOR CW-SSB              **
**
**  2.  DIRECT KEYING (PTT)                          **
**      GROUND FOR PA AMPLIFY MODE                  **
**
**  3.  NO CONNECTION                                **
**
**  4.  NO CONNECTION                                **
**
**  5.  REMOTE CONTROL OPERATION                     **
**      WHEN UNGROUNDED, PA CANNOT BE ACTIVATED.   **
**      (CUT INTERNAL GROUND TO ENABLE THIS)       **
**
**  6.  GROUND                                        **
**
**  7.  LED READOUT CONTROL                          **
**      WHEN UNGROUNDED, FRONT LED LIGHTS ARE     **
**      INOPERATIVE, EXCEPT FOR "RF" LED.       **
**      (CUT INTERNAL GROUND TO ENABLE THIS)       **
**
*****

```

GENERAL COMMENT ON PTT OPERATION:

FOR HARD KEYING THE AMP, PUT FRONT PANEL MODE SWITCH IN "FM" MODE. THEN CONNECT PIN 2 OF THE REMOTE PLUG TO YOUR XCVR'S PTT OUTPUT AND PIN 6 TO GROUND. THE XCVR'S PTT SHOULD GROUND ON XMIT AND REMAIN NEAR +12V ON RECEIVE. KEYING THE XCVR'S MIC WILL KEY THE POWER AMPLIFIER INTO THE "RF ON" CONDITION AND RETURN THE AMPLIFIER TO "RF OFF" IMMEDIATELY UPON UNKEYING.

R E M O T E C O N T R O L O P E R A T I O N

All amplifiers now have new, improved remote control capabilities as follows:

- Remote control the RF power amplifier
- Remote control of the GaAs FET preamplifier
- Improved GaAs FET preamp burnout protection

General Operation TE Systems amplifiers are factory wired for internal RF sensing operation with a capability for hard-keying. The hard-keying overrides the RF sensing and is done by wiring the remote socket's pin 2 to the transceiver's PTT.

Remote Operation Remote operation of the amplifier is done by cutting the internal shorting wire between pin 5 and pin 6 of the remote accessory socket. Remotely connecting these pins allows the amplifier to operate, and conversley, left unconnected the amplifier is disabled.

** The unit has the following remote functions available:

RF Sensing

- | | |
|----------------------------|---|
| RF Amp | Connect pin 5 and pin 6
Amplifier switch "On" |
| Preamp | Connect pin 5 and pin 6
Connect pin 3 and pin 4 (note pin 3 is +12 Vdc)
Amplifier switch "Off"; Preamp switch "Off" |
| RF Amp and Preamp | Connect pin 5 and pin 6
Connect pin 3 and pin 4 (note pin 3 is +12 Vdc)
Amplifier switch "On"; Preamp switch "Off" |
| RF Amp and Preamp disabled | Disconnect pin 5 and pin 6 |

Hard-keying

- | | |
|----------------------------|---|
| RF Amp | Connect pin 5 and pin 6
Connect pin 2 to transceiver PTT (gnd on xmit)
Amplifier switch "On" |
| Preamp | Connect pin 5 and pin 6
Connect pin 3 and pin 4 (note pin 3 is +12 Vdc)
Connect pin 2 to transceiver PTT (gnd on xmit)
Amplifier switch "Off"; Preamp switch "Off" |
| RF Amp and Preamp | Connect pin 5 and pin 6
Connect pin 3 and pin 4 (note pin 3 is +12 Vdc)
Connect pin 2 to transceiver PTT (gnd on xmit)
Amplifier switch "On"; Preamp switch "Off" |
| RF Amp and Preamp disabled | Disconnect pin 5 and pin 6; disable PTT from pin 2 |

TEMPERATURE CONSIDERATIONS:

NORMAL OPERATION OF THE AMPLIFIER USING INTERMITTENT DUTY (ICAS RATINGS) WILL ALLOW THE DISSIPATED POWER TO ADEQUATELY CONVECTION COOL TO THE AIR VIA THE HEATSINK FINS. THE FINS MUST BE MOUNTED FACING UPWARDS TO PERMIT THE COOLING, AND ADEQUATE AIR SPACE MUST BE ALLOWED (SEE INSTALLATION - MOUNTING). IT IS IMPORTANT THAT THE AMPLIFIER'S HEATSINK TEMPERATURE REMAIN WITHIN ACCEPTABLE LEVELS IN ORDER TO ALLOW PROPER AMPLIFIER OPERATION AND TO PREVENT DAMAGE TO INTERNAL COMPONENTS. THE ACCEPTABLE DUTY LEVELS ARE 50% OR LESS WITH TRANSMISSION DURATIONS LESS THAN 1 MINUTE AND HEATSINK TEMPERATURES LESS THAN +60 DEGREES CENTIGRADE.

IF THE HEATSINK TEMPERATURE DOES RISE ABOVE +65 DEGREES CENTIGRADE DURING OPERATION, A TEMPERATURE THERMOSTAT SWITCH WITHIN THE UNIT SWITCHES OFF THE POWER AMPLIFYING MODE. UPON SWITCHING, THE UNIT MUST COOL DOWN 15 DEGREES BEFORE THE SWITCH RESETS TO ALLOW THE AMPLIFIER TO AGAIN OPERATE. THIS FAILSAFE FEATURE PREVENTS ACCIDENTAL KEYING OR EXTENDED OPERATION FROM CAUSING AMPLIFIER DAMAGE.

IF LONG TRANSMISSIONS ARE REQUIRED, THE UNIT'S HEATSINK MUST BE COOLED BY EITHER FORCED AIR OR CONDUCTIVELY COOLED TO A COOL BODY. FORCED AIR IS THE BEST MEANS AND CAN BE PERFORMED WITH A SMALL BOXER TYPE FAN. TE SYSTEMS SUGGESTS ACTIVATING THE FAN FROM THE REMOTE ACCESSORY SOCKET AND INCORPORATING A TIME DELAY TO ALLOW THE FAN TO RUN SLIGHTLY OVER THE TOTAL TRANSMISSION TIME. CONTACT TE SYSTEMS OR ITS AGENT FOR APPLICATION ASSISTANCE ON THIS.

SECTION IV

THEORY OF OPERATION

RF POWER AMPLIFICATION: -----

WHEN A TRANSMITTED SIGNAL FROM A TRANSCEIVER IS APPLIED TO THE "XCVR" PORT AND THE UNIT IS SWITCHED ON, A SMALL AMOUNT OF SIGNAL IS COUPLED OFF, DETECTED, AND ACTIVATES THE T/R SWITCHING CONTROL CIRCUITRY. THE T/R RELAYS THEN CLOSE AND THE INCOMING SIGNAL TRAVELS TO THE RF POWER AMPLIFIER STAGES. UPON TERMINATION OF THE TRANSMITTER'S SIGNAL, THE T/R SWITCHING CIRCUITRY SENSES THE LOSS OF RF AND THE RELAYS RETURN TO THEIR NORMALLY CLOSED POSITION AND RF AMPLIFICATION IS TERMINATED.

THE RF POWER AMPLIFICATION SCHEME IS ACCOMPLISHED IN ONE STAGE CONSISTING OF TWO PARALLEL CONNECTED DEVICES. THE INCOMING SIGNAL IS DIVIDED AND DRIVES EACH DEVICE EQUALLY IN POWER AND IN PHASE. AFTER AMPLIFICATION, THE TWO OUTPUT STAGE POWERS ARE ADDED IN PHASE AND THE RESULTANT SIGNAL PASSES THROUGH THE T/R RELAY, THE OUTPUT FILTER, AND TO THE "ANTENNA" CONNECTOR.

EACH AMPLIFIER STAGE IS RUN IN A CLASS AB BIASED CONFIGURATION THAT ALLOWS GREATLY IMPROVED LINEARITY AND SMOOTH POWER TRANSFER PERFORMANCE. THE BIAS ARRANGEMENT IS HARD BIASED TO MAKE BIAS CHANGES LESS SENSITIVE TO RF LEVELS AND SILICON DIODES ARE USED TO PROVIDE THERMAL BIAS TRACKING IN THE RF POWER TRANSISTORS.

TE SYSTEMS HAS DESIGNED EACH STAGE TO HAVE A LOW Q PERFORMANCE. THIS ALLOWS WIDER RF RESPONSE WHILE KEEPING RF LOSSES AT A MINIMUM. THE RESULT IS A RF POWER AMPLIFIER WITH PERFORMANCE OVER A LARGE SEGMENT OF THE BAND WITHOUT RETUNING. EFFICIENCY IS KEPT HIGH BY STATE-OF-THE-ART DESIGN AND QUALITY COMPONENTS THAT MINIMIZE HEAT DISSIPATION AND REDUCE CURRENT CONSUMPTION.

ALL DC CONTROL CIRCUITS ARE APPROPRIATELY BYPASSED TO ELLIMINATE POSSIBLE RF SPURIOUS PRODUCTS. LOW FREQUENCY FEEDBACK CIRCUITS ARE INSTALLED WHERE NEEDED TO PREVENT LOW FREQUENCY SPURIOUS PRODUCTS ATTRIBUTABLE TO COMMON EMITTER VHF/UHF POWER TRANSISTORS.

FINALLY, THE AMPLIFIED SIGNAL IS APPLIED TO THE AMPLIFIER'S LOW PASS FILTER AND ON TO THE ANTENNA PORT CONNECTOR. EACH MODEL INCORPORATES A LOW PASS FILTER DESIGNED SPECIFICALLY FOR THE FREQUENCY RANGE WHICH ALLOWS MAXIMIZATION OF THE STOPBAND ATTENUATION FOR THE HARMONICS AND MINIMIZATION OF THE LOSS INBAND.

RECEIVE LNA:

WHEN THE FRONT PANEL PREAMP SWITCH IS ACTIVATED TO THE "ON" POSITION, THE INCOMING SIGNAL IS FED INTO THE RECEIVE PREAMP. THE SIGNAL IS APPLIED TO THE LOW NOISE GAAS FET DEVICE BY IMPEDANCE MATCHING THE SIGNAL TO THE GATE OF THE DEVICE. IN THIS CASE, IMPEDANCE MATCHING IS ACTUALLY NOISE FIGURE MATCHING SUCH THAT A MINIMUM NOISE FIGURE PERFORMANCE IS ACHIEVED. THE AMPLIFIED SIGNAL IS THEN FREQUENCY MATCHED INTO A BANDPASS FILTER AND THEN TO THE 50 OHM OUTPUT (ANTENNA PORT).

SELECTIVITY IS ACHIEVED BY THE FREQUENCY SELECTIVE INPUT MATCH AND THE SINGLE POLE FILTER AT THE DEVICE'S OUTPUT. THE USE OF THE ADDITIONAL OUTPUT SELECTIVITY FURTHER ENHANCES OUT-OF-BAND SIGNAL REJECTION WITH ONLY MINIMAL IN-BAND SIGNAL ATTENUATION. THE GAIN VARIATION IS TYPICALLY 1 - 2 DB WITHIN 10% OF THE CENTER BAND. THIS IS SUFFICIENT ENOUGH TO NOT CAUSE RECEIVING VARIATIONS WITHIN THE BAND.

PROPRIETARY CIRCUITRY IS EMPLOYED TO INHIBIT THE TRANSMIT SIGNAL FROM DAMAGING THE SENSITIVE LOW-NOISE GAAS FET DEVICE. THEREFORE, THE APPLICATION OF HIGH POWER TRANSMIT SIGNALS CANNOT CAUSE GAAS FET DEVICE FAILURE. UPON TRANSMITTING, THE T/R RELAYS ACTIVATE IMMEDIATELY TO SWITCH THE TRANSMITTED SIGNAL AWAY FROM THE PREAMP AND INTO THE RF POWER AMPLIFIER SECTION. ADDITIONALLY, SINCE THE PREAMP IS PROTECTED FROM RF BURNOUT, OTHER ATMOSPHERIC SIGNAL TRANSCIENTS COMING FROM THE ANTENNA ARE LESS LIKELY TO CAUSE GAAS FET DEVICE FAILURE.

T/R SWITCHING:

AS MENTIONED IN THE SECTION "RF POWER AMPLIFICATION" THE AMPLIFIER'S TRANSCIEVE SWITCHING IS DONE BY RELAYS DRIVEN BY THE T/R SWITCHING DC CONTROL CIRCUIT. WITH NO TRANSMITTED SIGNAL APPLIED, THE MAIN T/R RELAY REMAINS ALWAYS IN THE RECEIVE POSITION AND (WITH THE PREAMP OPTION) THE RECEIVE PREAMP RELAY MAY OR MAY NOT BE SWITCHED IN.

WHEN TRANSMISSION COMMENCES, THE MAIN T/R RELAY IS DRIVEN TO SWITCH THE INCOMING SIGNAL TO THE AMPLIFYING STAGES. IF OPTIONED, THE PREAMP RELAY IS SIMULTANEOUSLY DRIVEN TO SWITCH OUT THE PREAMP AND DISCONNECT ITS DC VOLTAGE.

IN ALL FRONT PANEL SWITCHING CONFIGURATIONS, THE RECEIVE GAAS FET PREAMP IS PROTECTED FROM RF BURNOUT ATTRIBUTABLE TO THE INCOMING RF SIGNAL OR THE AMPLIFIED SIGNAL. THIS UNIQUE FEATURE ALLOWS THE USAGE OF HIGH QUALITY, LOW-NOISE GAAS FET DEVICES IN THE RECEIVE PREAMP YIELDING SUPERIOR RECEIVING PERFORMANCE UNOBTAINABLE HERETOFORE.

BLOCK DIAGRAM

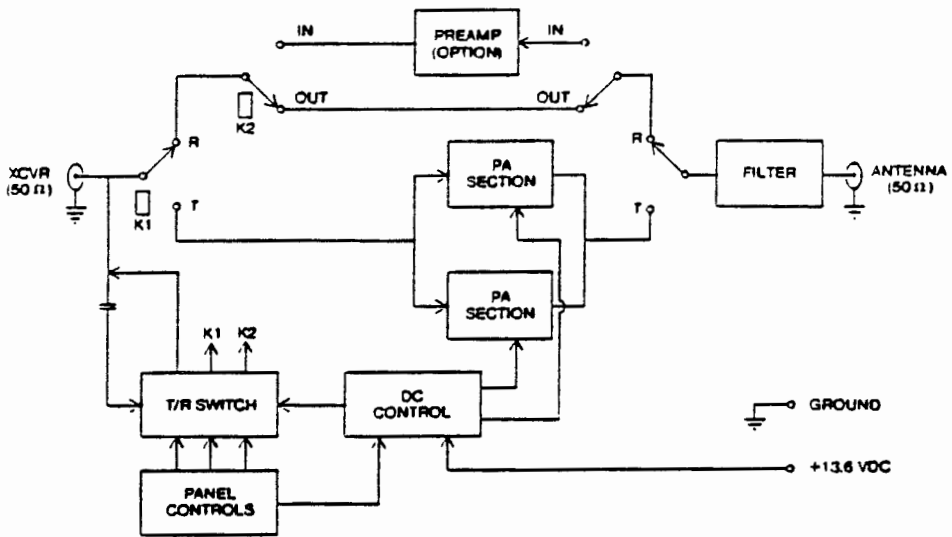

SYSTEM BLOCK DIAGRAM

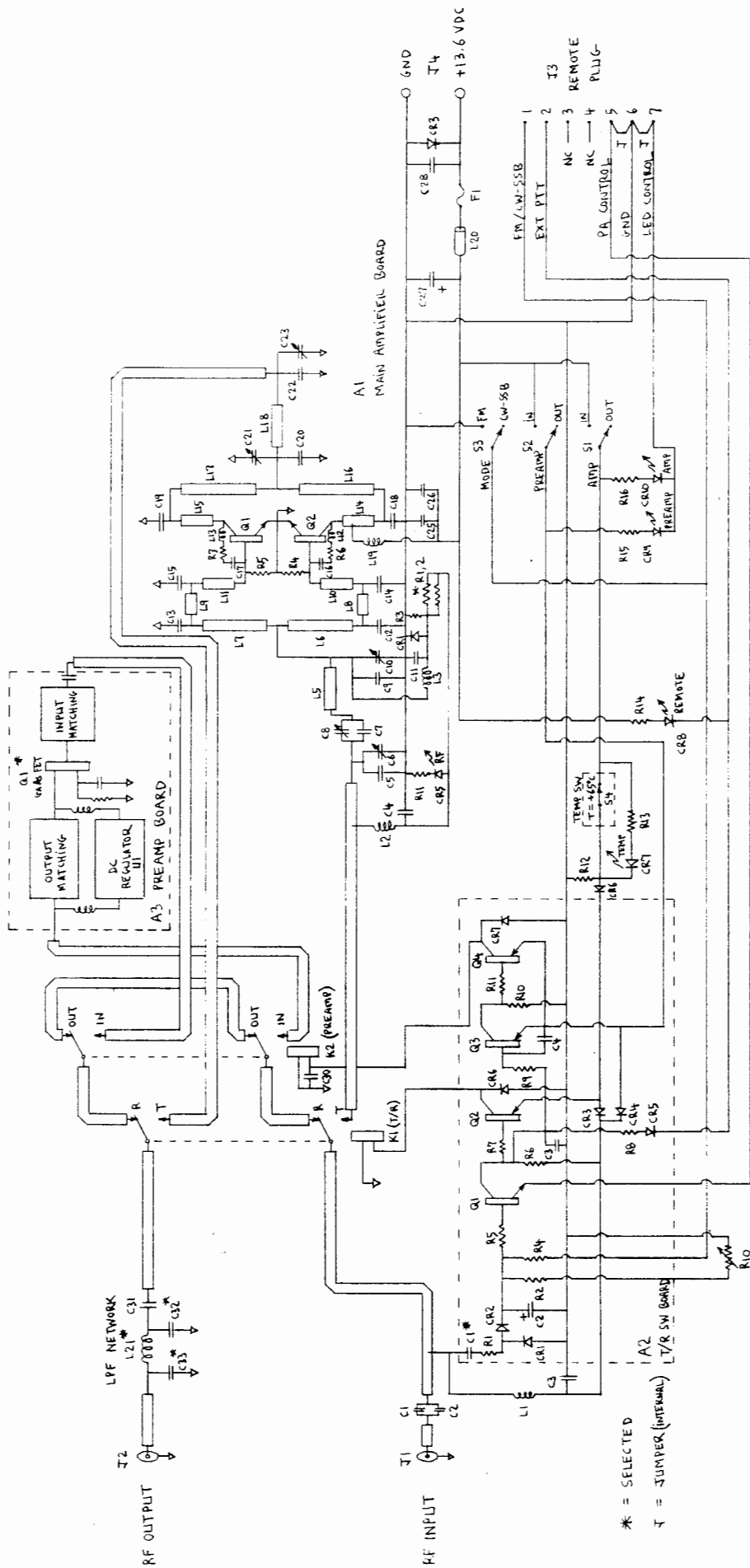

SCHEMATIC DIAGRAM
MODEL 0510G

 ***** PARTS LIST *****

 ***** NUMBER: FLO510G, REV - *****
 ***** TE SYSTEMS *****

REF. DESIGNATION	QUANTITY	DESCRIPTION
A1	1	MAIN AMP BOARD
A2	1	T/R SWITCH PC BOARD
A3	1	GAAS FET PREAMP (50MHZ)
A1C1, A1C2, A1C3	3	500PF CHIP CAP.
A1C4, A1C11	2	.001MF DISC CAP.
A1C6, A1C23	2	250PF VARIABLE CAP.
A1C8	1	115PF VARIABLE CAP.
A1C9	1	SELECTED METAL CAP.
A1C12, A1C13, A1C18 A1C19, A1C31	5	1000PF METAL CAP.
A1C16, A1C17	2	.05UF DISC CAP.
A1C20	1	SELECTED METAL CAP.
A1C25	1	1000PF SM CAP.
A1C26, A1C28	2	.01UF DISC CAP.
A1C27	1	470UF ELECTROLYTIC
A1C30	1	.05UF DISC CAP.
A1C31	1	1000PF METAL CAP.
A1C32	1	SELECTED METAL CAP.
A1C33	1	SELECTED METAL CAP.
A1C5, A1C7, A1C10, A1C14 A1C15, A1C21, A1C22		NOT USED
A2C1	1	SELECTED DISC CAP.
A2C2	1	5UF ELECTROLYTIC
A2C3	1	.001UF DISC CAP.
A2C4	1	SELECTED CAP.
A1CR1	2	SILICON DIODE, 3A
A1CR3	1	SILICON DIODE, 6A
A1CR5, A1CR7, A1CR8	3	LED-RED
A1CR6	1	SILICON DIODE, 1A
A1CR9, A1CR10	2	LED-GREEN
A2CR1, A2CR2, A2CR5	3	SILICON SW DIODE
A2CR3, A2CR4, A2CR6, A2CR7	4	SILICON DIODE, 1A
A1F1	1	35A FUSE
A1FH1	1	FUSEHOLDER
A1H1	14	4-40X1/4 SHCS
A1H2	4	4-40X5/16 SHCS
A1H3	12	4-40X3/8 SHCS
A1H4	8	4-40X1/2 SHCS
A1H5	38	#4 SPLIT LKWSHRS
A1H6	2	#4 FLAT WASHERS .016
A1H7	18	#4 FLAT WASHERS .032
A1H8	8	4-40X1/4 BLACK OX

A1J1-2	2	RF CONNECTOR (SELECTED)
A1J3	1	DC REMOTE JACK
A1J4	1	DC POWER PLUG (M)
A1J5	1	DC POWER JACK (F)
A1J6	1	DC REMOTE PLUG
A1J7, A1J8, A1J9	3	LED MOUNT ASSY
A1K1	1	RELAY 2FORMC
A1K2	1	RELAY 2FORMC
A1L1, A1L3	2	RF CHOKE
A1L2	1	COIL CHOKE
A1L12, A1L13	2	RF CHOKE
A1L19	1	COIL CHOKE
A1L30	1	LARGE FB CHOKE
A1L31	1	COIL, FILTER
A1MP1	1	HEATSINK
A1MP2	1	FRONT PANEL 05106
A1MP3	1	REAR PANEL
A1MP4	1	COVER
A1MP5	1	HEAT PLATE
A1MP6	2	CONN. SPACER
A1MP7	1	KNOB
A1MP8	4	THREADED STANDOFF
A1Q1-2	2	TRANSISTOR NPN MRF492
A2Q1	1	TRANSISTOR NPN SW
A2Q2, A2Q3, A2Q4	3	TRANSISTOR PNP SW
A1R1-2	2	RESISTOR, SELECTED
A1R3		NOT USED
A1R4-5	2	RESISTOR 3.3 OHM, 1W
A1R6-7	2	RESISTOR 15 OHM, 1W
A1R10	1	POT 500K, .5W
A1R11-16	6	RESISTOR 1K, .25W
A2R1	1	RESISTOR 100, 1W
A2R2	1	RESISTOR 22K, .25W
A2R4	1	RESISTOR 5.6K, .25W
A2R5, A2R9	2	RESISTOR 4.7K, .25W
A2R6	1	RESISTOR 1K, .25W
A2R7, A2R11	2	RESISTOR 10K, .25W
A2R8, A2R10	2	RESISTOR 470, .25W
A1S1, A1S2	2	SWITCH SPDT W/LED
A1S3	1	SWITCH SPDT
A1S4	1	THERMOSTAT 65 DEG C

SECTION V

MAINTENANCE

INTRODUCTION

THIS SECTION OF THE MANUAL CONTAINS PERFORMANCE TEST AND ADJUSTMENT PROCEDURES DESIGNED TO ALLOW FIELD CHECKS AND ADJUSTMENT OF THE UNIT. AS WITH ALL ELECTRONIC EQUIPMENT, SUCH ADJUSTMENTS MAY BE NECESSARY FROM TIME TO TIME TO ALLOW THE UNIT TO PERFORM AT ITS OPTIMUM PERFORMANCE LEVEL. THE FOLLOWING TESTS AND ADJUSTMENTS SHOULD BE PERFORMED BY PERSONS TECHNICALLY KNOWLEDGEABLE IN THE SPECIFIC AREA OF CONCERN. ACCURACY OF RESULTS WILL DEPEND ON THE QUALITY OF MEASUREMENT EQUIPMENT; THEREFORE, THE USE OF HIGH-GRADE, LAB QUALITY TEST EQUIPMENT IS ENCOURAGED.

RF PA ADJUSTMENT

REMOVE THE EIGHT SCREWS THAT SECURE THE AMPLIFIER COVER AND LIFT OFF THE U-SHAPED COVER. NOTE THE FRONT AND BACK OF THE COVER SO THAT IT CAN BE EASILY REFITTED AFTER TESTING. THIS IS DESIRABLE SINCE THE COVER IS NOT SYMMETRIC AND REFITTING IS MORE EASILY FACILITATED WITH THE PROCEDURE OUTLINED. MOUNT THE AMPLIFIER UNDER TEST WITH THE FINS DOWNWARD AND THE INTERNAL COMPONENTS FACING UPWARDS.

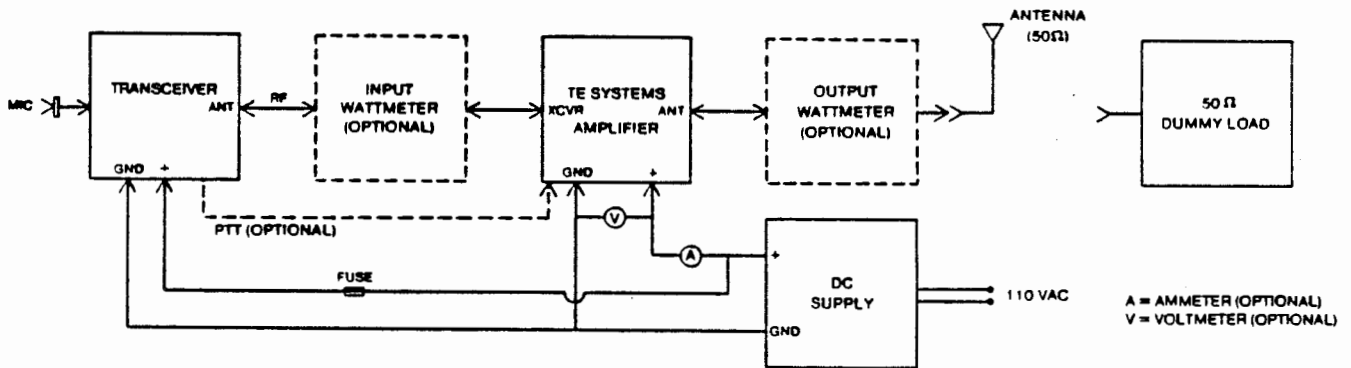

OPERATIONAL / TEST SET-UP FOR AMPLIFIER

NEXT CONNECT THE AMPLIFIER UNDER TEST AS SHOWN IN THE OPERATIONAL/TEST DIAGRAM ABOVE. THE FOLLOWING TECHNICAL POINTS OF INTEREST SHOULD BE NOTED BEFORE ACTUAL RF TESTING COMMENCES:

A) CAPABILITY OF MEASURING THE VOLTAGE APPLIED TO THE UNIT DURING FULL POWER DRIVE IS NECESSARY IN ASSURING PROPER OPERATION OF THE UNIT. IF THE DC VOLTAGE IS NOT 13.6 VDC UNDER FULL LOAD, A SIGNIFICANT POWER OUTPUT DROP MAY BE EVIDENT, THEREBY, ASSURING SPECIFICATION NONCOMPLIANCE.

B) ALL CABLE CONNECTIONS SHOULD BE DONE WITH HIGH QUALITY LOW LOSS 50 OHM CABLES THAT USE GOOD QUALITY RF CONNECTORS USABLE AT THE TEST FREQUENCY. BNC AND N STYLE CONNECTORS ARE EXCELLENT AND UHF CONNECTORS MAY BE USED ALSO IF PROPER ATTENTION IS GIVEN TO THEIR ASSEMBLY AND CONNECTION.

C) THE ANTENNA OR 50 OHM LOAD SHOULD PRESENT A VERY LOW VSWR TO THE AMPLIFIER SO THAT TUNING ADJUSTMENT CAN BE OPTIMIZED FOR A 50 OHM SYSTEM AND MAXIMUM FORWARD POWER IS OBTAINABLE.

--- PERFORMANCE CHECKS ---

1. OUTPUT POWER

WITH THE SYSTEM CONNECTED AS SHOWN ABOVE IN THE OPERATIONAL/TEST SET-UP DIAGRAM AND ALL SWITCHES "OFF", APPLY DC VOLTAGE AND FULL RF DRIVE. THE OUTPUT POWER METER SHOULD SHOW POWER OUT SLIGHTLY LESS THAN THE INPUT DRIVE POWER.

NEXT MAKING SURE A LOW VSWR ANTENNA LOAD IS CONNECTED, TURN THE AMPLIFIER IN/OUT SWITCH TO "ON". THE OUTPUT POWER METER SHOULD RISE GREATLY TO THE SPECIFIED POWER OUT AND THE CURRENT METER (IF CONNECTED) SHOULD INDICATE THE APPROXIMATE SPECIFIED CURRENT. THE INPUT POWER METER SHOULD INDICATE THE LEVEL OF APPLIED INPUT POWER AND SHOW VERY LITTLE, IF ANY, REFLECTED POWER. IF THE POWER SPECIFICATIONS ARE NOT MET WITHIN 5%, THE UNIT CAN BE CHECKED FURTHER PER THE TUNING ADJUSTMENTS SECTION BELOW.

 --- TUNING ADJUSTMENTS ---

2. TUNING ADJUSTMENTS

THE FOLLOWING DIAGRAM AND CHART SHOW THE TUNING ADJUSTMENTS THAT CAN BE PERFORMED TO THE AMPLIFIER UNIT. THE UNIT SHOULD BE CONNECTED AS DESCRIBED ABOVE AND CALIBRATED, ACCURATE TEST INSTRUMENTATION BE USED.

TOP VIEW WITH COVER REMOVED

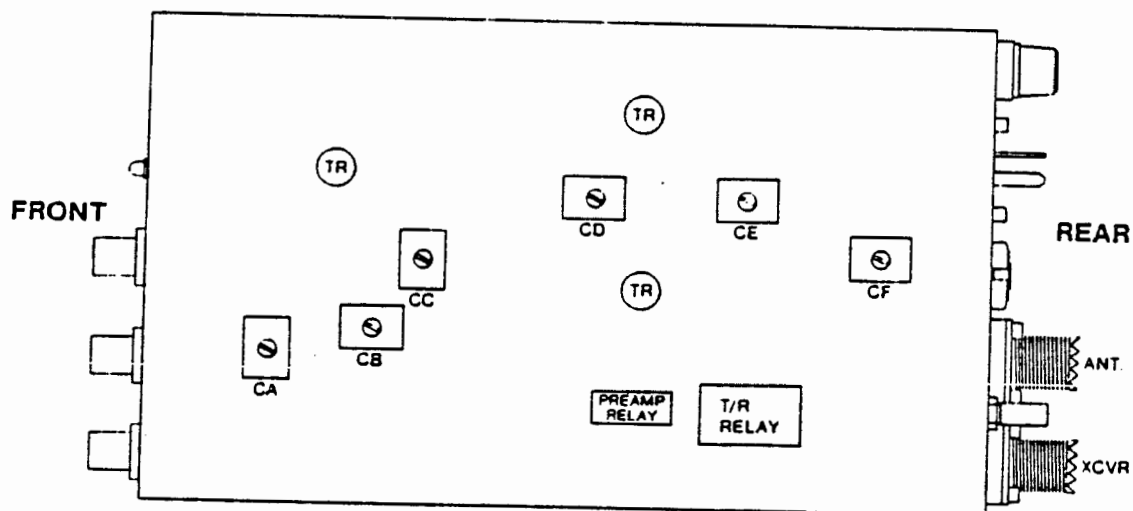

```

*****
***
***          MODEL 0510G TUNING CAPACITOR KEY          ***
***
*****
**
**          CA - NOT USED                               **
**          CB - INPUT VSWR TUNING ADJUSTMENT          **
**          CC - INPUT VSWR TUNING ADJUSTMENT          **
**          CD - NOT USED                               **
**          CE - NOT USED                               **
**          CF - OUTPUT POWER TUNING ADJUSTMENT        **
**
*****

```

A. INPUT VSWR

WITH THE AMPLIFIER UNDER TEST CONNECTED AS SHOWN ABOVE IN THE OPERATIONAL/TEST SET-UP DIAGRAM AND INPUT POWER APPLIED AT THE FREQUENCY SPECIFIED, ADJUST TRIMMER CAPACITORS "CB" AND "CC" FOR MINIMUM REFLECTED POWER AS MEASURED ON THE INPUT POWER METER. THE FINAL INPUT VSWR SHOULD BE <1.5:1 ACROSS THE BAND.

B. OUTPUT POWER

NEXT CHECK THE UNIT FOR OUTPUT POWER AS MEASURED BY THE OUTPUT POWER METER. THE READING SHOULD BE WITHIN 5% OF THE SPECIFIED LEVEL. IF IT IS NOT, THE TRIMMER CAPACITOR "CF" CAN BE ADJUSTED FOR MAXIMUM OUTPUT POWER. WHILE THE AMPLIFIER IS FACTORY TUNED FOR MAXIMUM POWER INTO A VERY LOW VSWR OUTPUT LOAD, SOME INSTALLATIONS CAN BE FURTHER OUTPUT POWER OPTIMIZED BY PERFORMING THE ABOVE ADJUSTMENT. AS A FINAL CHECK, THE AMPLIFIER SHOULD BE CHECKED FOR SPECTRUM CLEANLINESS USING A HIGH QUALITY LABORATORY SPECTRUM ANALYZER.

RECEIVE LNA ADJUSTMENT:

PROPER ALIGNMENT OF THE LNA CAN ONLY BE PERFORMED USING INSTRUMENTATION CAPABLE OF MEASURING AMPLIFIER NOISE FIGURE AND ASSOCIATED GAIN. EQUIPMENT SUCH AS THE HEWLETT PACKARD 8970A OR THE EATON 2075 ARE IDEAL FOR SUCH MEASUREMENTS. ALTERNATIVELY, SEPARATE GAIN AND NOISE FIGURE MEASUREMENTS CAN BE MADE USING OTHER EQUIPMENT BUT THE MEASUREMENT ACCURACY MAY NOT BE GOOD, ESPECIALLY WITH NOISE FIGURES BELOW 1 DB.

ASSUMING RECENT NOISE FIGURE INSTRUMENTATION IS AVAILABLE, THE NOISE SOURCE IS CONNECTED TO THE "ANTENNA" PORT OF THE AMPLIFIER UNDER TEST, AND THE INSTRUMENTS I.F. INPUT IS CONNECTED TO THE AMPLIFIER'S "XCVR" PORT. USING A SWEPT OSCILLOSCOPE DISPLAY ACROSS THE SPECIFIED FREQUENCY BAND, ALL THE TRIMMERS AND TUNING COILS ARE ADJUSTED FOR MINIMUM NOISE FIGURE AND MAXIMUM ASSOCIATED GAIN. THE FINAL TUNING RESULTS SHOULD AGREE WITH THE SPECIFIED DATA TO THE FOLLOWING TOLERANCE PERCENTAGES: NOISE FIGURE 20%, GAIN 10%. NOTE THAT THE INPUT TRIMMERS CAN BE TUNED EITHER SIDE OF MAXIMUM GAIN WITH THE NOISE FIGURE MINIMIZATION OCCURRING ON ONLY ONE SIDE. THE INPUT TRIMMER(S) SHOULD ALWAYS BE TUNED FOR MINIMUM NOISE FIGURE AT THE FREQUENCY OF INTEREST.

TE SYSTEMS LNA DESIGN EMPLOYS AN ADDITIONAL OUTPUT SELECTIVITY SECTION TO ENHANCE OUT-OF-BAND SIGNAL REJECTION. THIS INCREASED AMPLIFICATION ϕ HAS MINIMAL IN-BAND GAIN-REDUCTION BUT GREATLY REMOVES THE POSSIBILITY OF ADJACENT OUT-OF-BAND SIGNAL MIXES OCCURRING FROM UNDESIRED SIGNAL OVERLOADING.